

A photograph showing a person in a red jacket sitting in a blue wheelchair. They are positioned next to the open rear door of a white bus with blue and yellow stripes. A black dog is standing on the ground next to the wheelchair. The bus has a wheelchair accessibility symbol on the door and the word 'FREQUE' visible on its side.

FIRETRACE[®]

AUTOMATIC FIRE SUPPRESSION SYSTEMS

MOBILITY VEHICLE

Fire Protection Solutions



Approximately 2,200 Bus or School Bus Fires occur annually with many more unreported.

Source: National Fire Protection Association



Protect your passengers. Give them enough time to safely exit the vehicle.

THE PROBLEM

A fire in a vehicle is a dangerous situation. For those who face mobility challenges the danger is far greater. Even a short delay in exiting a burning vehicle can result in serious injury or death.

As a result, some local and state authorities have mandated that vehicles carrying mobility challenged passengers **MUST** be equipped with automatic fire suppression systems to protect against fire and give operators and rescuers additional time to assist passengers in exiting the vehicle.

For the thousands of vehicles already on the road which were not designed with a fire suppression system, a system must be retrofit into the vehicle. However, finding a fire suppression system that is reliable, easily installed, and flexible enough to be retrofit into a variety of vehicles has been problematic, until Firetrace.

FIRETRACE ADVANTAGES:

- ✦ Fast, reliable fire detection
- ✦ Requires no power to operate, offering 24/7 protection
- ✦ Installs quickly in new or existing vehicles
- ✦ Tolerant of the harsh working environment, including temperature extremes, vibration and dirt/dust
- ✦ Doesn't interfere with maintenance of vehicles

THE SOLUTION: EFFECTIVE FIRE SUPPRESSION

Firetrace offers a unique approach to protecting many of the fire-prone areas of these vehicles. Firetrace systems detect fire using the proprietary Firetrace Detection Tubing. This heat sensitive polymer tubing is pressurized and reacts to the heat and radiant energy of a fire by bursting, thus releasing the fire suppression agent.

Why Firetrace is ideal for vehicle fire protection:

- ✦ Firetrace Detection Tubing tolerates the vibration, dirt, and temperature extremes of the environments in which the vehicles operate
- ✦ Firetrace systems are self-operated and require no power to activate
- ✦ No false activations, systems are failsafe and react only to fire or extreme heat
- ✦ Very easy to install and maintain
- ✦ Cost effective protection for engines, electrical systems or HVAC

HOW IT WORKS



Indirect Release Systems

Firetrace is a totally self-contained fire detection and suppression system. It requires no electricity to operate and offers automatic 24/7 protection for the vehicle.

The proprietary red Firetrace Detection Tubing is the key to detecting fires where they start. By routing the tubing through the compartments to be protected, Firetrace's detection can get right to the source of the fire. Firetrace tubing is constructed from a proprietary polymer composition; it is immune to the dust, vibration and shocks associated with these vehicles. When the tubing is exposed to the heat and radiant energy from a fire, the tubing bursts, activating the system.

AREAS PROTECTED:

- ✦ Engine compartment
- ✦ Generator
- ✦ Electrical systems

Firetrace systems will activate automatically in the event of a fire.

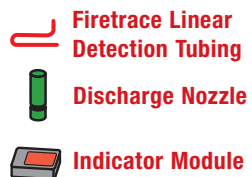
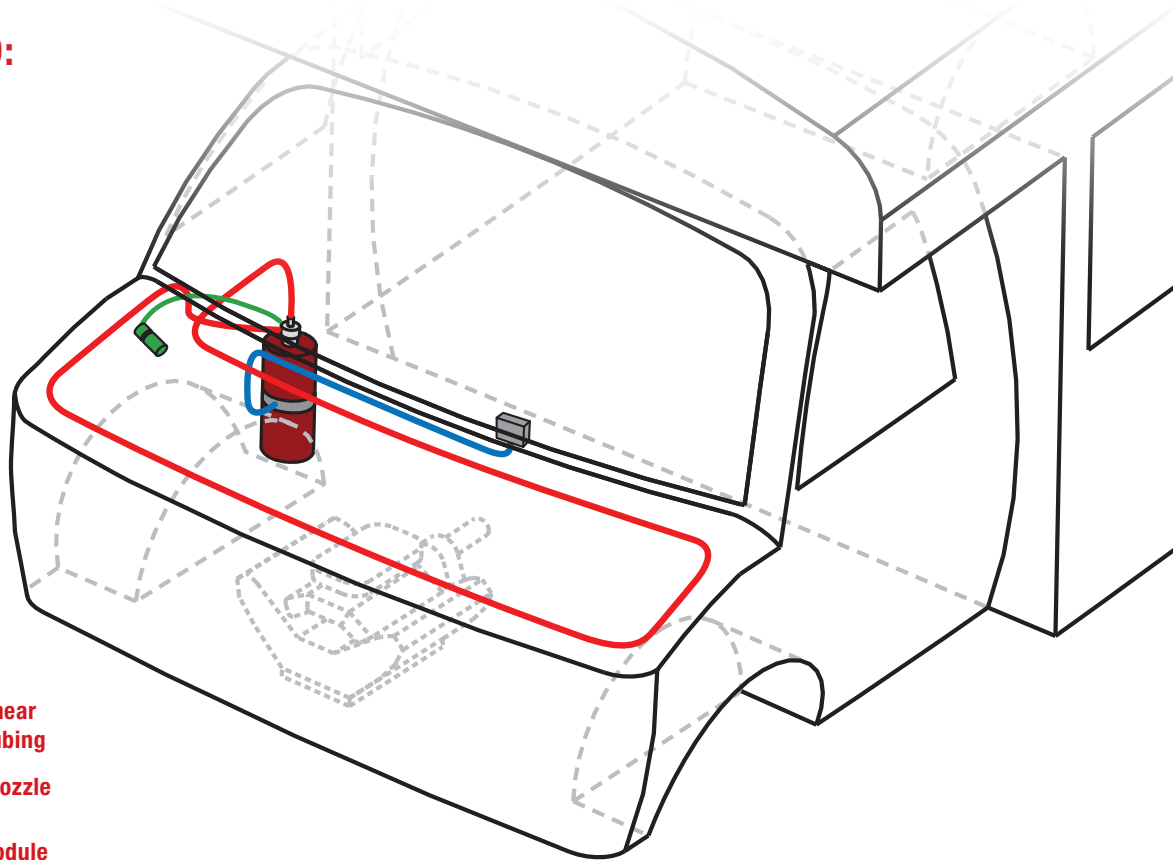

The Firetrace Detection Tubing (pictured above and below) can be run across all potential hazard areas, ensuring detection is close to the most probable fire sources.



FIRETRACE®

AUTOMATIC FIRE SUPPRESSION SYSTEMS

FIRETRACE® Vehicle Applications

Firetrace is in use on more than 10,000 buses worldwide. In fact, Firetrace receives reports monthly on buses being saved from fire thanks to their Firetrace systems. Firetrace systems can be easily retrofitted to your existing fleet by maintenance personnel or by authorized Firetrace distributors.

In 2001, the worldwide rights to Firetrace were purchased by Firetrace USA, a group of fire suppression industry veterans who saw the value in creating fire suppression systems for “micro-environments.” This concept is simply providing supplemental protection that suppresses fire quickly within the protected space before larger room or building systems would activate. As a result of this supplemental protection, fire damage, both direct and collateral, and costs associated with cleanup and downtime are significantly reduced or eliminated. Available in multiple system sizes (ranging from one pound systems to 50 pound systems) utilizing a variety of fire suppressing agent options, Firetrace is now the choice fire suppressing system for virtually any enclosed application.

Firetrace can be fitted in virtually any bus, new or existing.



Firetrace currently has more than 20 international approvals and listings, including: UL, CE, FM, ULC & ISO9001. Approvals and listings vary by system type and agent.

Firetrace is available exclusively through our worldwide distributors, each of which has been properly trained in the installation and maintenance of Firetrace systems. To locate the Firetrace distributor nearest you please contact us at:

World Headquarters

Firetrace International

15690 N. 83rd Way, Suite B
Scottsdale, AZ 85260 USA

1-866-607-1218 (US and Canada)

1-480-607-1218 (Elsewhere)

1-480-315-1316 (Fax)

info@firetrace.com

Europe, Middle East and

Africa Regional Office

Firetrace International Limited

Unit 12, Fairlawn Business Park,
Bonehurst Road, Red Hill
Surrey RH1 5GH, United Kingdom

+44 (0) 1293 780 390

+44 (0) 1293 780 399 (Fax)

emea@firetrace.com

Firetrace International Ltd

(Middle East) LLC

PO Box 442042

Dubai, United Arab Emirates

+971 56 7599490

www.firetrace.com